

Survey Date

The 2004 queue length surveys were conducted on Wednesday 13th October 2004 during the periods defined below:

- AM Peak 0700 – 1000
- INTER Peak 1130 – 1430
- PM Peak 1500 – 1900

The 2006 queue length surveys were conducted on Tuesday 25th, Wednesday 26th and Saturday 29th April 2006 during the periods defined below:

- AM Peak 0700 – 1000
- INTER Peak 1130 – 1430
- PM Peak 1600 – 1900

2004 WEEKDAYS AVERAGE QUEUES

2004 WEEKDAYS MAXIMUM QUEUES

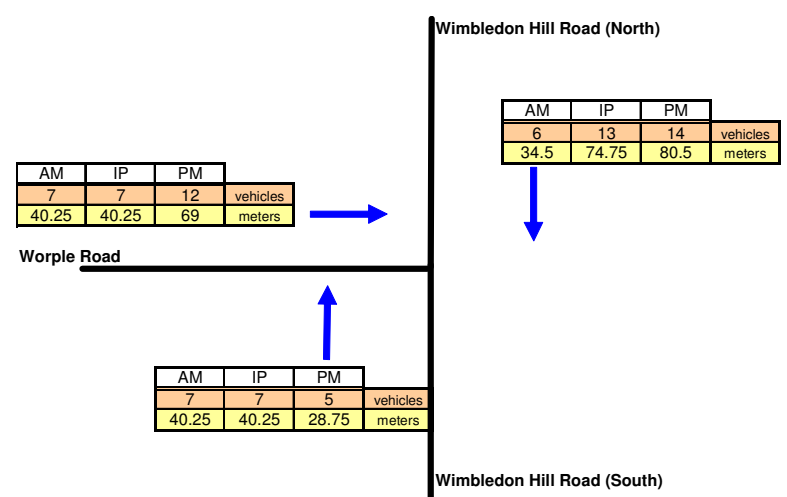
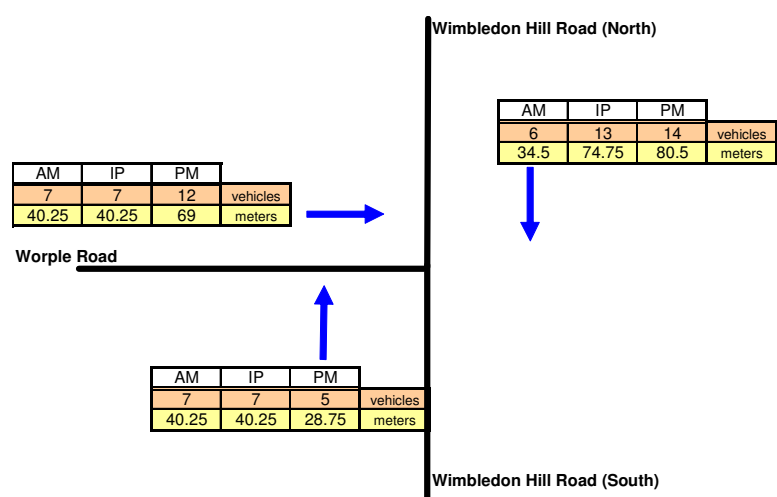
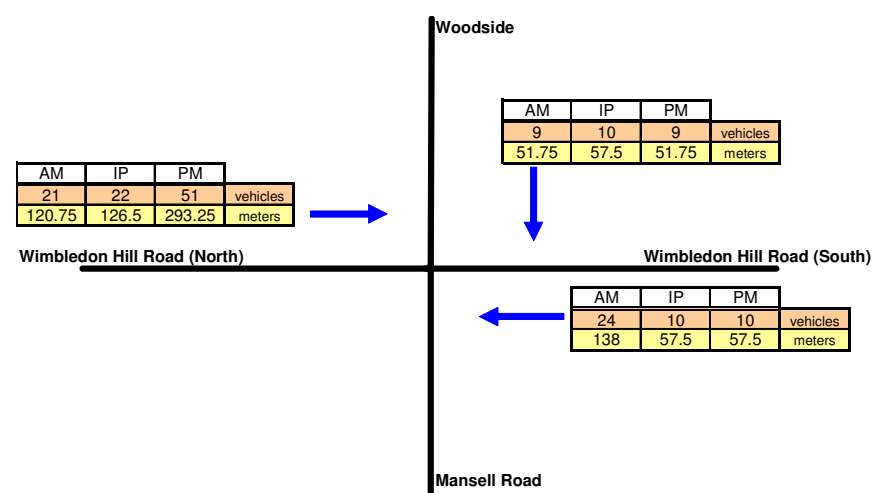
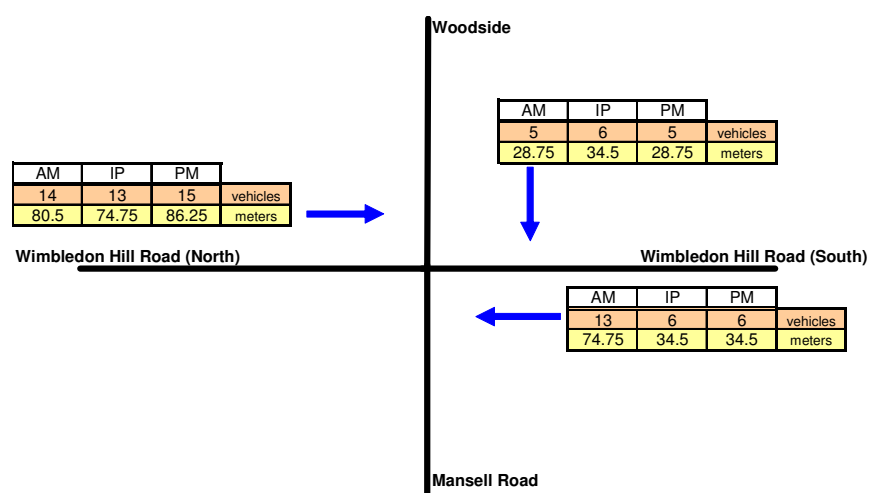
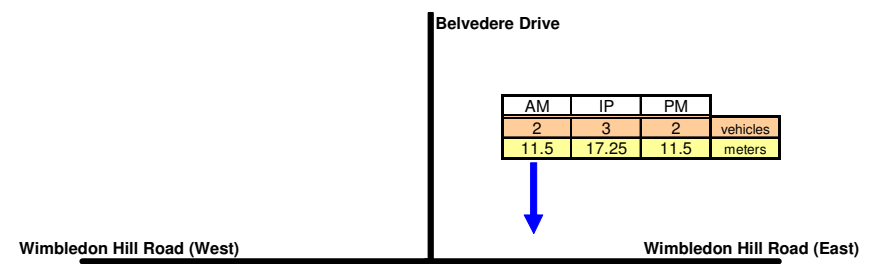
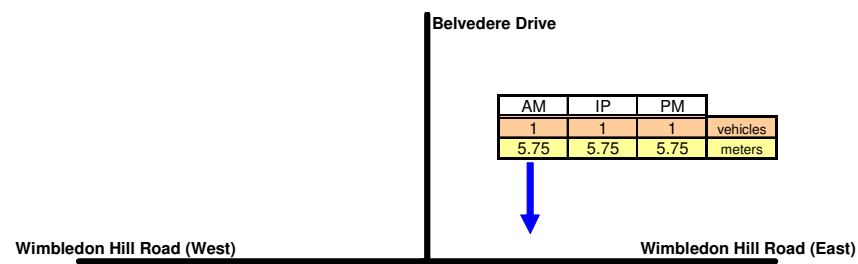
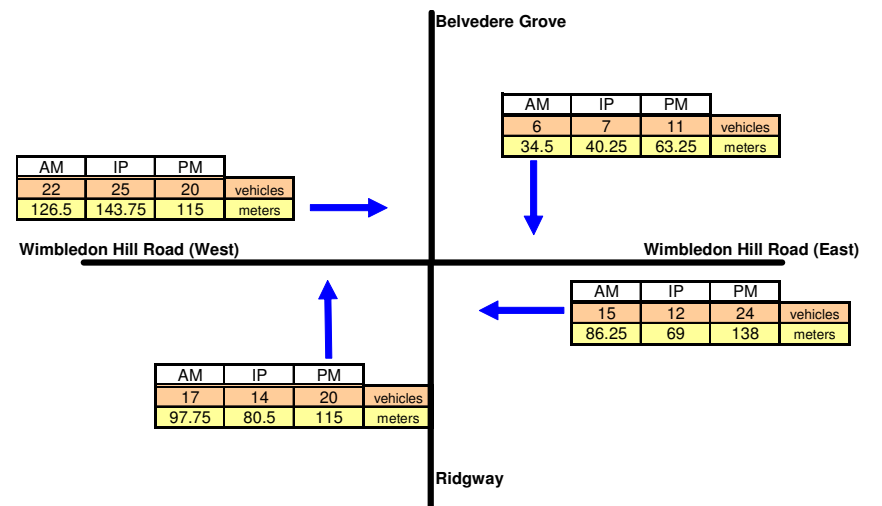
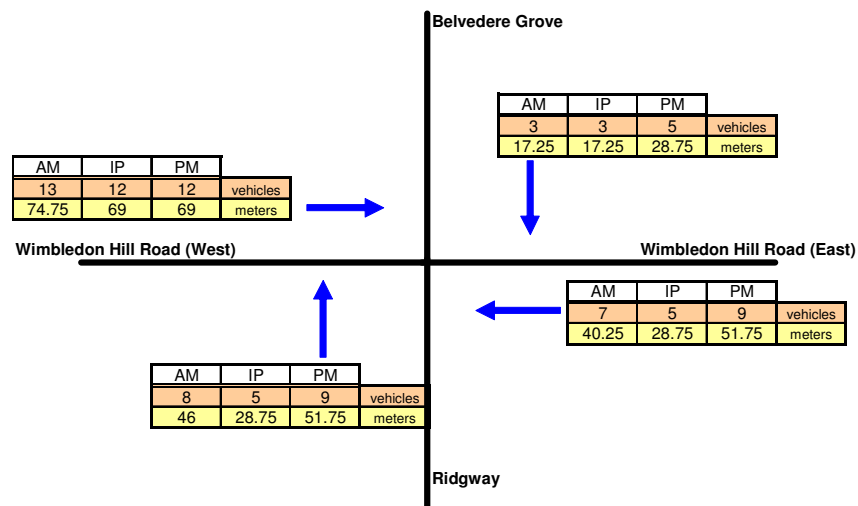

2004 WEEKDAYS AVERAGE QUEUES

2004 WEEKDAYS MAXIMUM QUEUES

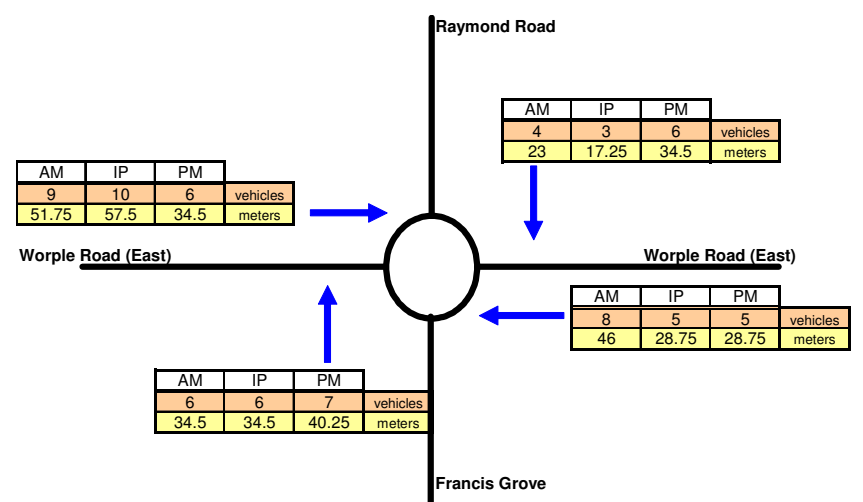
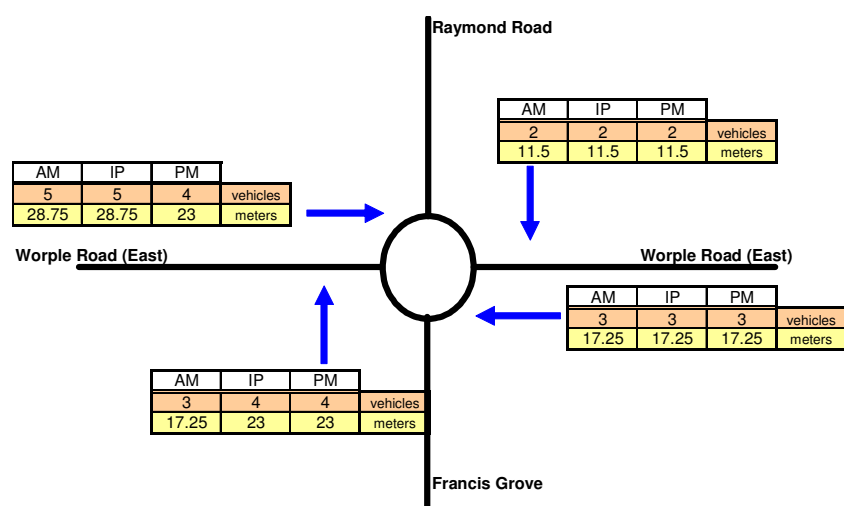
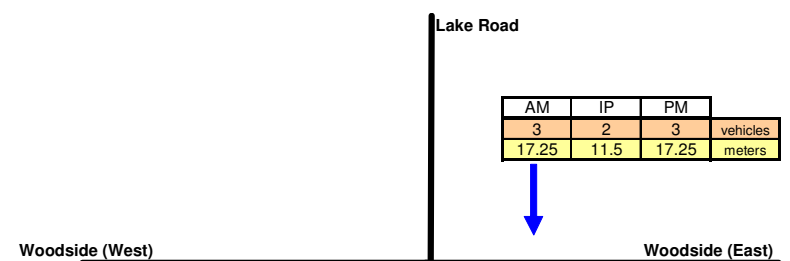
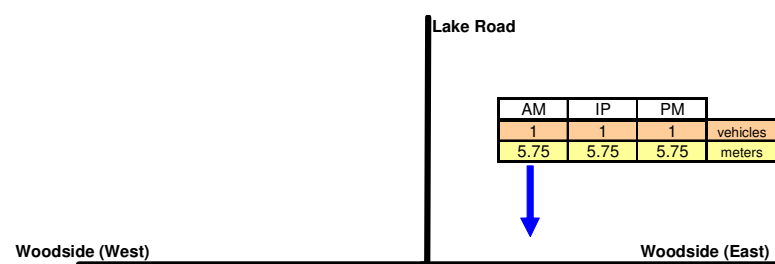
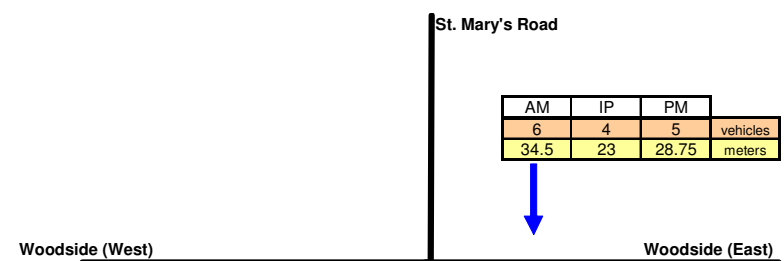
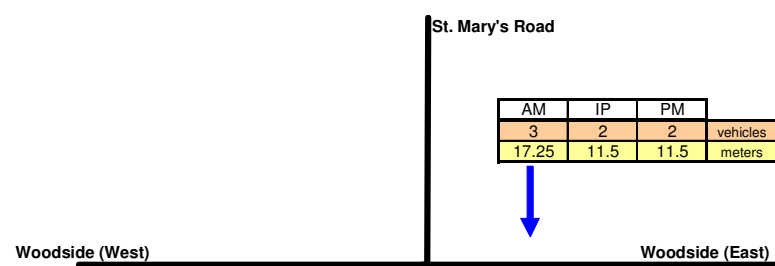
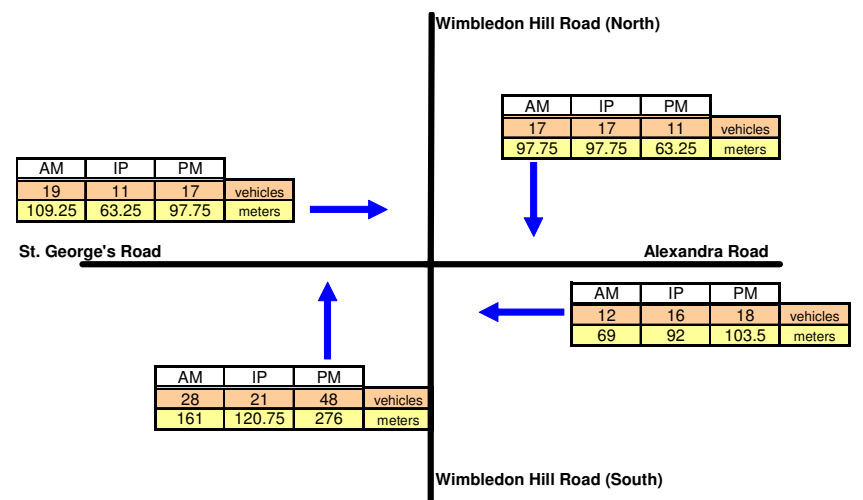
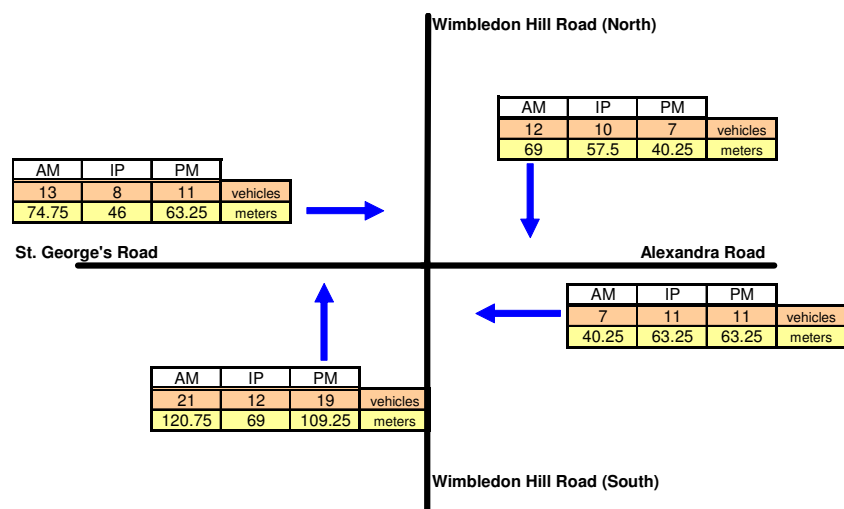

2006 WEEKDAYS AVERAGE QUEUES

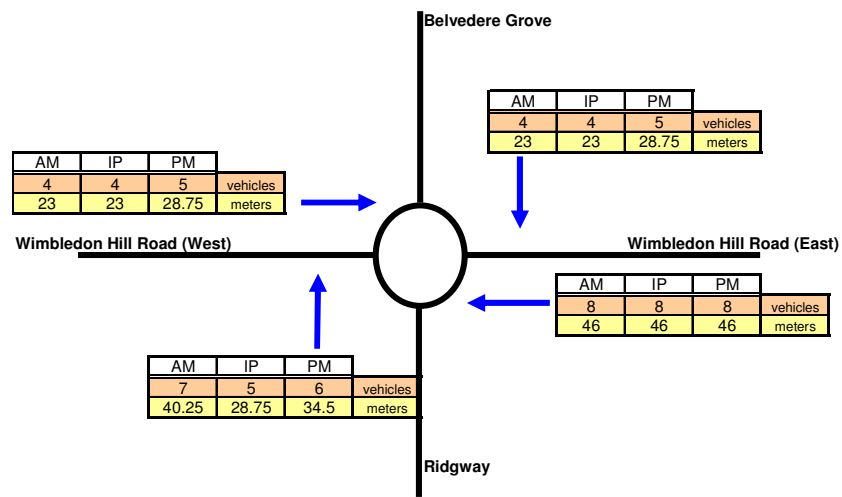

2006 WEEKDAYS MAXIMUM QUEUES

